

Dual Hose Reel

P/N: ART.593.174.6

Length (in/mm)	19.7/500
Width (in/mm)	17.3/440
Height (in/mm)	18.2/463
Weight (lbs/kgs)	82/37.2 with hoses
Hose Length (ft/m)	50/15

Features: 50 ft dual hose reels with manual rewind. The reel has a durable powder coat finish with retractable rewind handles. Specifications include hose on reels.

American Rescue Technology, Inc. 2780 Culver Ave. Kettering, Ohio 45429
Tel. 937-293-6240 Fax 937-293-7049

GENESIS
RESCUE SYSTEMS

HOSE REELS



- AVAILABLE IN:**
- * **MANUAL REWIND - 10,500 psi & 5,000 psi models**
Pt# ART.HRM.050 (w/ 50 ft. hose)
Pt# ART.HRM.100 (w/100 ft. hose)
 - * **ELECTRIC REWIND - 10,500 psi & 5,000 psi models**
Pt# ART.HRE.050 (w/50 ft. hose)
Pt# ART.HRE.100 (w/100 ft. hose)

NOTE: 3 ft. Pigtails are Standard on all reels. Please specify hose length if special order pigtails are required.

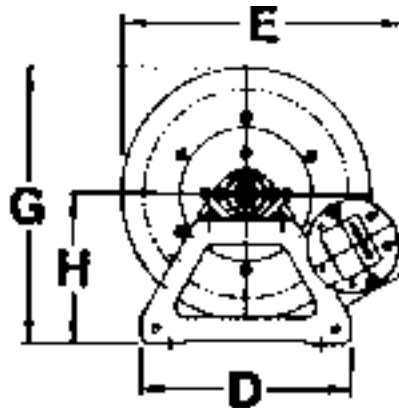
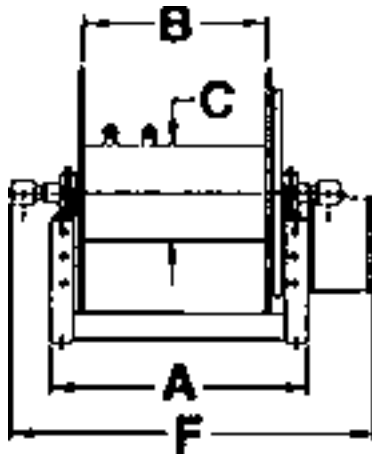

REEL DIMENSIONS (Inches)

	A	B	C	D	E	F	G	H	WEIGHT (without hose)
MANUAL REWIND	13	8	6	14	16.5	17.5	18.12	9.88	32 Lbs.
ELECTRIC REWIND	13	8	6	14	19	20.5	18.12	9.88	50 Lbs.



HOWELL RESCUE SYSTEMS, INC.

2673 Culver Ave., Kettering, OH 45429

800 228-7612

937 290-0522 *FAX 937 290-0528

Visit our Website howellrescue.com or E-mail info@howellrescue.com